

Double fork positioner for 1-2 pallets

DPK-C

The double fork positioner DPK-C can pick up one or two pallets through hydraulic fork positioning. The distance between the pallets can be reduced to zero. The strong frame construction maximises service life and safe working. The compact design gives excellent visibility.

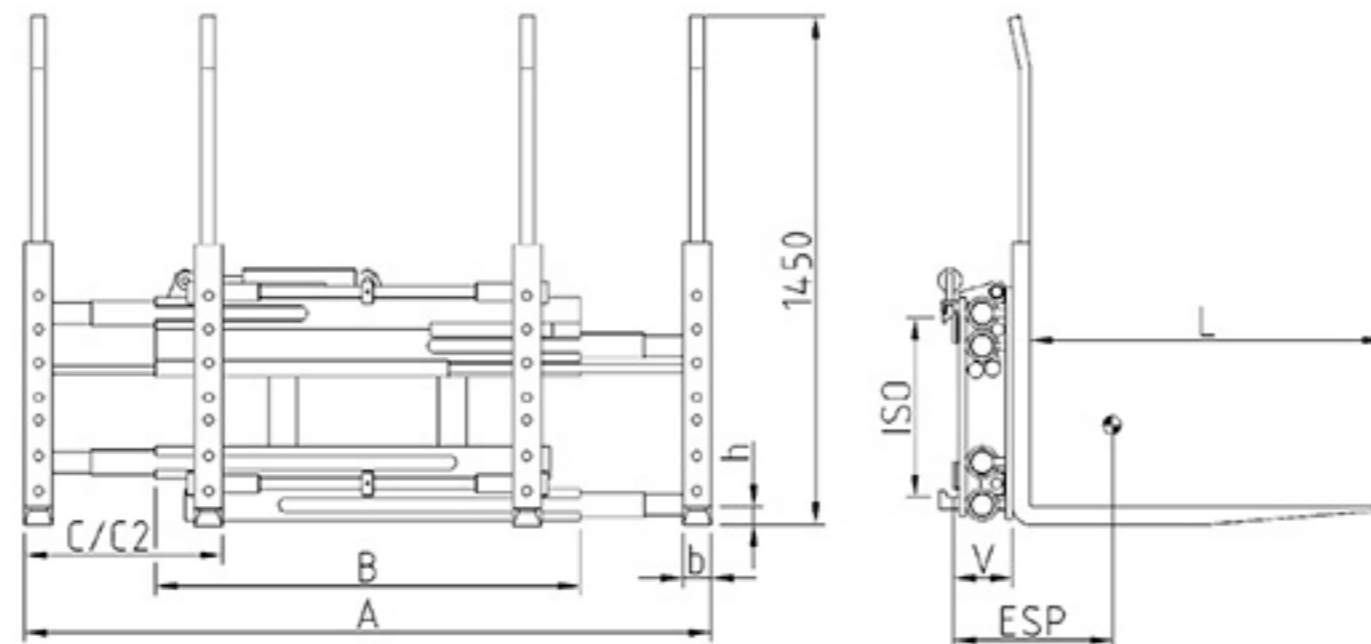

C=560 mm

C2= 660 mm



type	capacity kg LC mm	lift truck to LC mm	ISO	B mm	A mm	forks b x h x L mm	sideshift mm	V LLC mm	ESP COG mm	weight kg
DPK 16-C	1600/600	1,5-1,8/600	II	1050	560-1790	80x40x1200	+/- 100	165	240	475
DPK 22-C	2200/600	2,0-2,5/500	II	1200	560-1940	80x40x1200	+/- 100	165	260	495
DPK 22-C2	2200/600	2,0-2,5/500	II	1200	660-2140	80x40x1200	+/- 100	165	248	515
DPK 25-C	2500/600	2,5/600	II	1200	560-1940	80x50x1200	+/- 100	165	260	535
DPK 25-C2	2500/600	2,5/600	II	1200	660-2140	80x50x1200	+/- 100	165	248	555
DPK 30-C	2600/600	3,0/500	III	1200	560-1940	80x50x1200	+/- 100	165	250	540
DPK 30-C2	2600/600	3,0/500	III	1200	660-2140	80x50x1200	+/- 100	165	250	565
DPK 32-C	2800/600	3,5/500	III	1200	560-1940	80x50x1200	+/- 100	185	235	585
DPK 32-C2	2800/600	3,5/500	III	1300	660-2140	80x50x1200	+/- 100	185	235	620
DPK 35-C	3200/600	3,0/600-4,0/500	III	1200	560-1940	80x60x1200	+/- 100	185	230	635
DPK 35-C2	3200/600	3,0/600-4,0/500	III	1300	660-2140	80x60x1200	+/- 100	185	230	670
DPK 40-C	4500/600	4,0/600-5,0/600	III	1400	560-1940	80x60x1200	+/- 150	195	215	750
DPK 40-C2	4500/600	4,0/600-5,0/600	III	1400	660-2140	80x60x1200	+/- 150	195	210	780
DPK 50-C	5500/600	5,0-6,0/600	IV	1400	560-1940	80x60x1200	+/- 150	212	200	1010

- 2 hydraulic functions required
- includes hoses and couplings
- constant sideshift as standard
- C2 models have 660 mm fork set spread

- no sideshift for ISO II, III, and ISO IV upon request, data change please ask
- optional with high visibility load backrest at no extra charge

 automatic lubrication system: add
 DPK 16 - 30 C
 (sideshift top and bottom)
 DPK 35 - 100 C (sideshift top)
 upon request

- single pair control upon request
- scanner holder on request

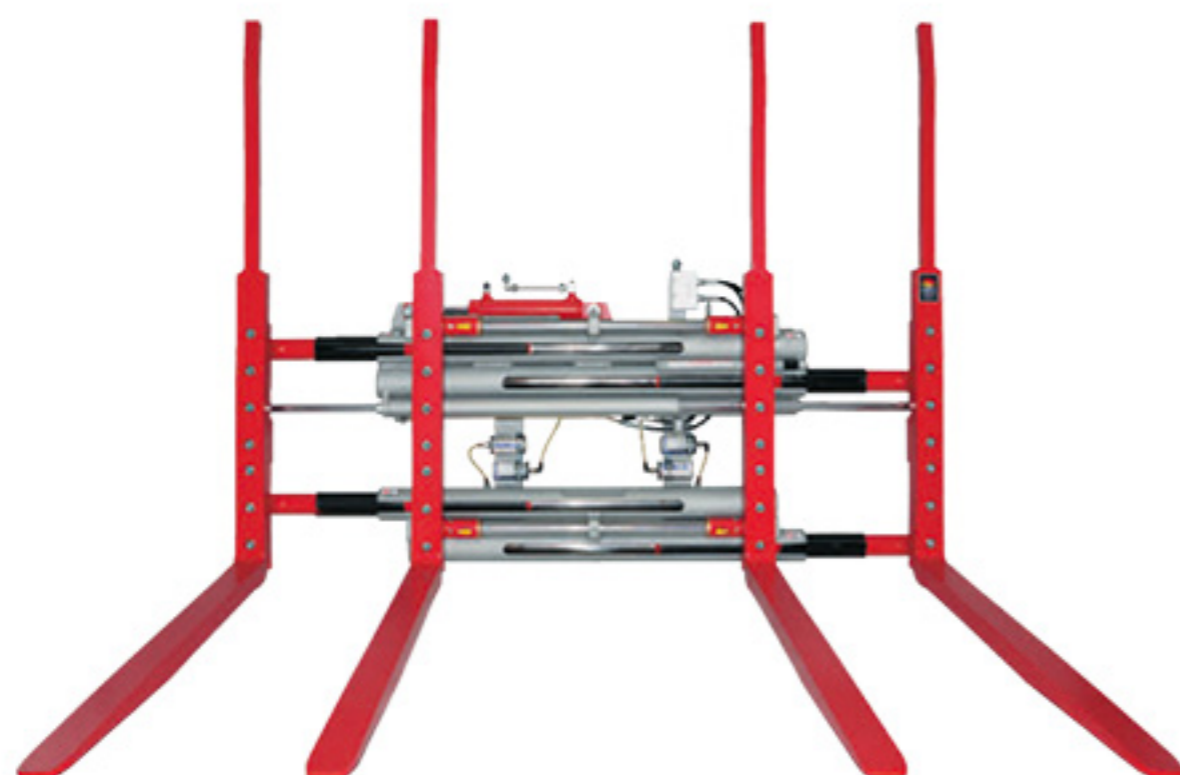



 Forklift Attachments

More than 70 years experience

Double fork positioner for 2-4 pallets

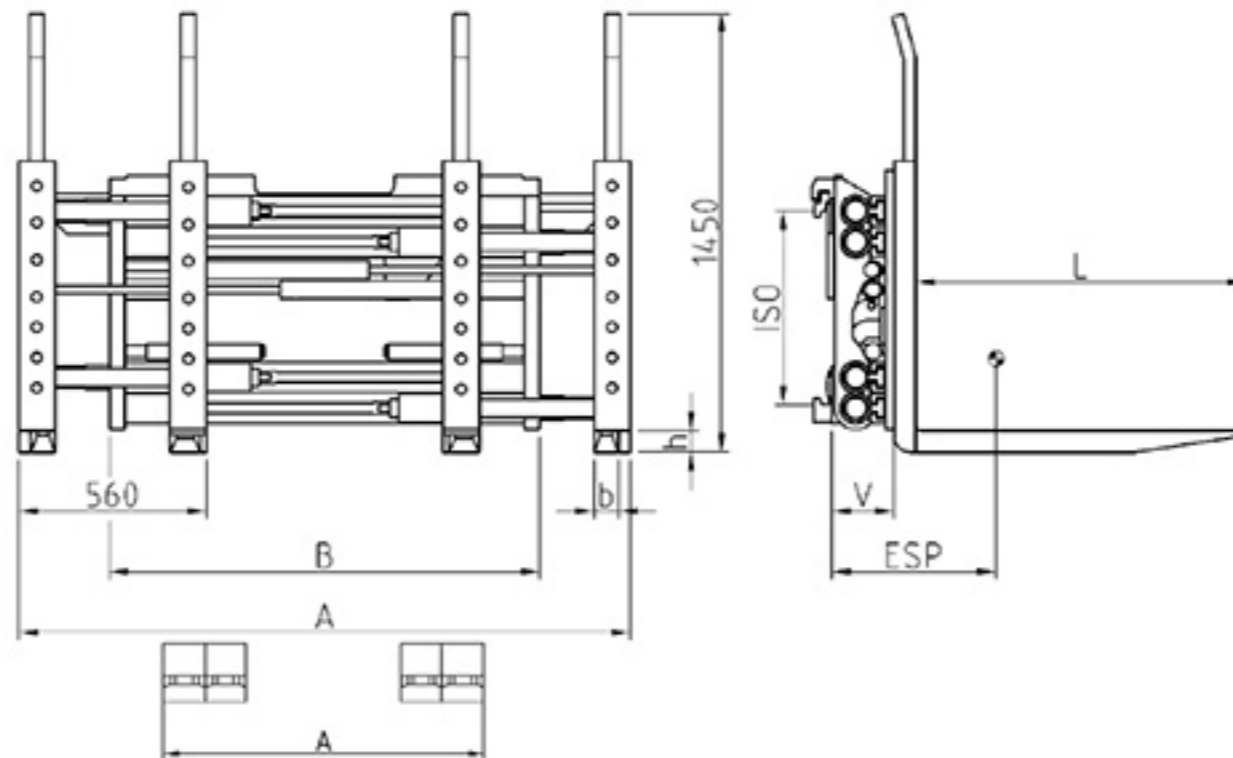
The double fork positioner **DPK-C** can pick up two or four pallets through hydraulic fork positioning and extra fork length. The distance between the pallets can be reduced to zero. The strong frame construction maximises service life and safe working. The compact design gives excellent visibility. With the extended forks it is possible to load and unload vehicles from one side. Sideshift is fitted as standard.



type	capacity kg LC mm	lift truck to LC mm	ISO	B mm	A mm	forks b x h x L mm	sideshift mm	V LLC mm	ESP COG mm	weight kg
DPK 34-C	1600/1200	3,5/500-4,0/500	III	1200	560-1940	80x60x2400	+/- 100	185	620	815
DPK 45-C	2500/1200	4,0/600-5,0/500	III	1400	560-1940	80x70x2400	+/- 150	195	520	970
DPK 48-C	2800/1200	5,0/600	III	1400	560-1940	80x70x2400	+/- 150	195	505	995
DPK 55-C	3000/1200	5,0/600	IV	1400	560-1940	80x70x2400	+/- 150	212	490	1130
DPK 60-CP	3600/1200	6,0-7,0/600	IV	1420	560-1940	80x70x2400 100x60x2400	+/- 150	212	435	1320
DPK 80-CP	4600/1200	8,0/600	IV	1420	560-1940	80x70x2400 100x60x2400	+/- 150	215	445	1380
DPK 100-CP	5600/1200	10,0/600-8,0/900	IV	1800	560-1960	80x80x2400 100x70x2400	+/- 150	220	465	1720
DPK 120-CP	7000/1200	8,0/1100	IV	2000	680-2090	120x80x2400	+/- 150	230	640	1900
DPK 180-CP*	9600/1200	15,0/600	integral	2550	750-2080	160x70x2400	+/- 200	390	415	3800

- 2 hydraulic functions required
- includes hoses and couplings
- constant sideshift as standard
- no sideshift for ISO II, III and ISO IV upon request, data change, please ask



- automatic lubrication system: DPK 34 - 100 C (sideshift top) upon request
- single pair control upon request
- scanner holder on request

* weight without brackets / COG is without brackets, from front edge of brackets / LLC is from front edge of brackets

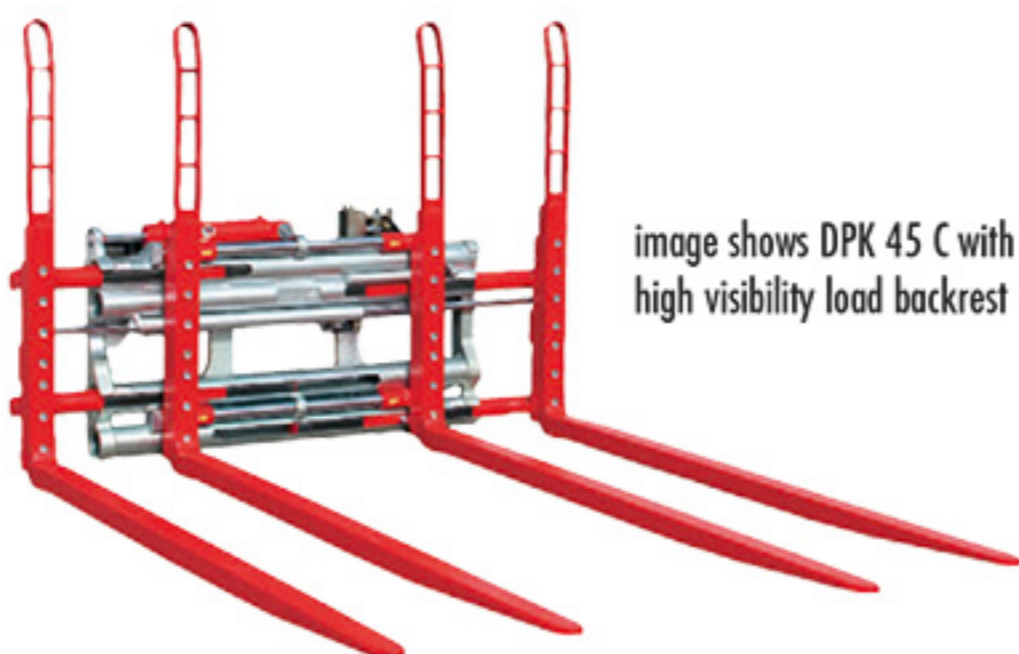
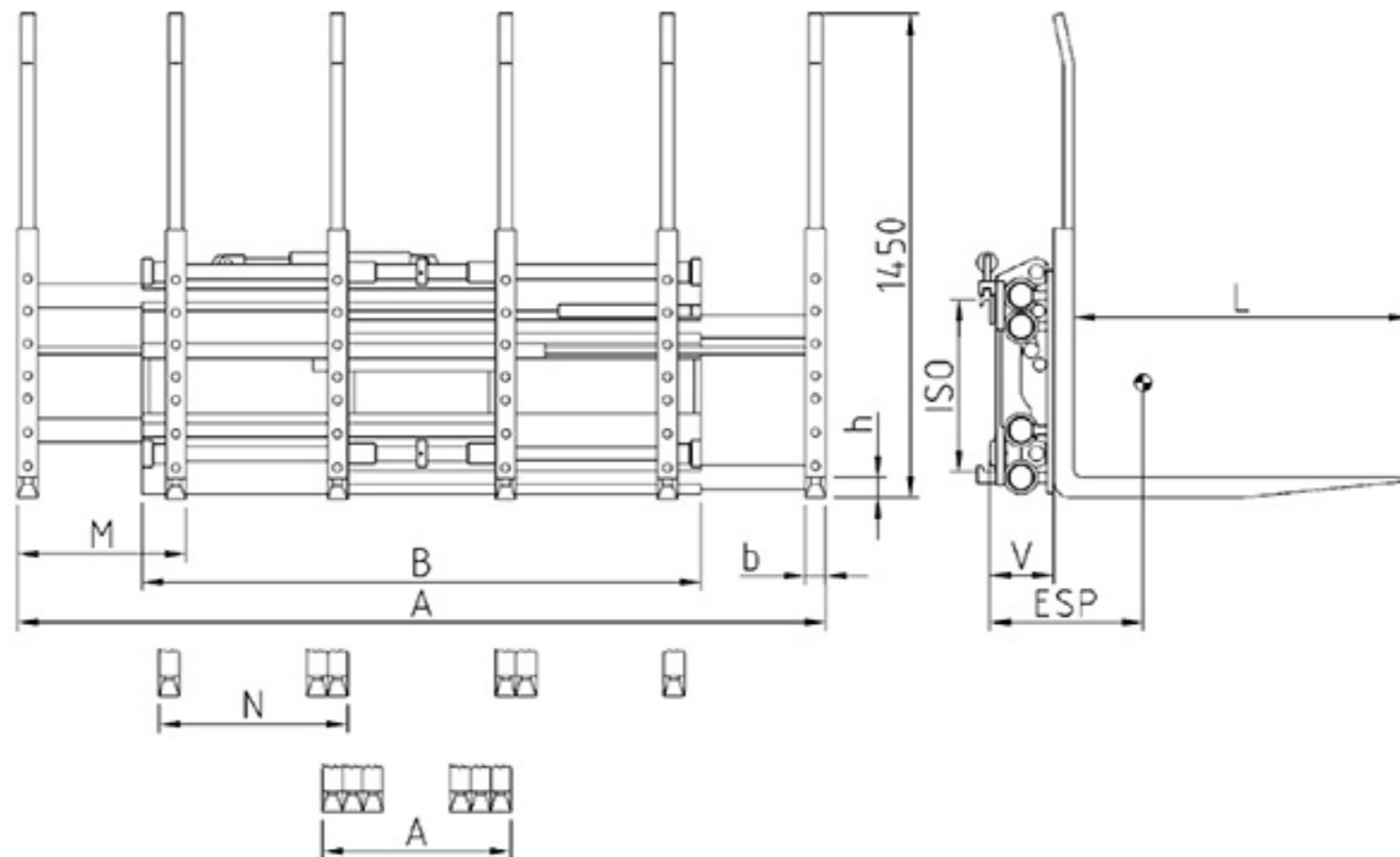

image shows DPK 45 C with option:
high visibility load backrest

Triple fork positioner for 1-2-3 pallets

DRPK-C

The triple fork positioner DRPK-C can pick up one, two or three pallets through hydraulic fork positioning. The distance between the pallets can be reduced to zero. The strong frame construction maximises service life and safe working. Sideshift is fitted as standard.



type	capacity kg LC mm	lift truck to LC mm	ISO	B mm	A mm	M/N mm	forks b x h x L mm	sideshift mm	V LLC mm	ESP COG mm	weight kg
DRPK 25-C	2500/600	2,5/600	II	1630	560-2285	500/560	60x50x1200	+/- 100	173	230	745
DRPK 30-C	3000/600	3,0-3,5/600	III	1465	560-2240	530/590	60x50x1200	+/- 100	173	235	730
				1630	560-2285	500/560				235	745
				1795	560-2450	500/560				233	770
DRPK 45-C	3800/600	4,0-5,0/600	III	1630	560-2285	500/560	60x60x1200	+/- 100	173	240	800
				1795	560-2450					237	825
				2285	560-2940					225	945
DRPK 50-C	4500/600	5,0/600	IV	1980	560-2760	510/570	60x70x1200	+/- 100	233	235	1220

- 2 hydraulic functions required
- includes hoses and couplings
- constant sideshift as standard

- no sideshift for ISO II, III and ISO IV upon request, data change, please ask

- automatic lubrication system:
DRPK 25-C - DRPK 50-C upon request
- single pair control upon request
- scanner holder on request



image shows DRPK 45 C with option:
high visibility load backrest

DURWEN
Forklift Attachments

More than 70 years experience

Multi fork positioner

with load-extender for 1-2 and 1-2-3 pallets

The double fork positioner VDPK-C with load-extender can load and unload lorries from one side.

Additionally, the attachment has all the advantages of the double fork positioner, i.e. sideshift, slim forks, handling of one or two pallets and positioning the pallets together. The stroke of the load-extender is sufficient for the standard vehicle width of 2400 mm. Model VDRPK-C made for handling of 1, 2 or 3 pallets.

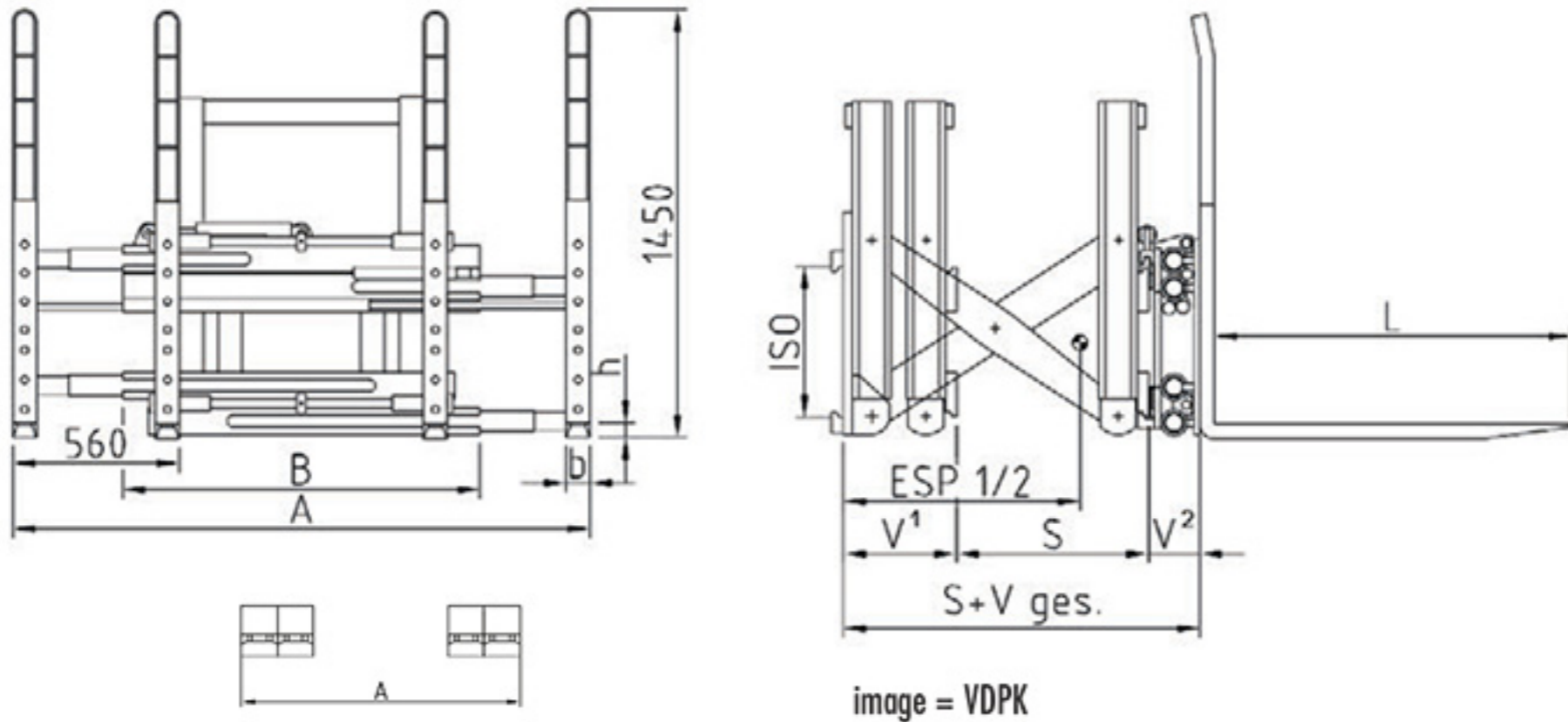

image = VDPK

double fork positioner for 1+ 2 pallets

type	capacity kg LC mm	lift truck to LC mm	ISO	B mm	A mm	forks b x h x L mm	stroke S mm	sideshift mm	V1+V2 LLC mm	ESP I COG I mm	ESP II COG II mm	weight kg
VDPK 25-C	800/1840	3,5/500	II/III	1200	560-1940	80x40x1200	620	+/- 100	520	340	870	970
VDPK 45-C	2200/1840	4,5- 5,0/600	III	1200	560-1940	80x50x1200	650	+/- 100	545	365	820	1160
VDPK 50-C	2200/1840	5,0/600	IV	1200	560-1940	80x50x1200	650	+/- 100	545	365	820	1180

triple fork positioner for 1, 2 and 3 pallets

type	capacity kg LC mm	lift truck to LC mm	ISO	B mm	A mm	forks b x h x L mm	stroke S mm	sideshift mm	V1+V2 LLC mm	ESP I COG I mm	ESP II COG II mm	weight kg
VDRPK 45-C	2500/1840	5,0/600	III	1550	560-2285	60x50x1200	650	+/- 125	553	400	680	1395
VDRPK 60-C	2600/1840	6,0/600	IV	1550	560-2285	60x60x1200	650	+/- 125	553	440	720	1455
VDRPK 70-C	2700/1840	7,0/600	IV	1550	560-2285	60x60x1200	650	+/- 125	553	455	735	1485
VDRPK 80-C	3600/1840	8,0/600	IV	1550	560-2285	60x60x1200	650	+/- 125	600	370	760	1880

- 3 hydraulic functions required
- includes hoses and couplings
- constant sideshift as standard

- solenoid valve upon request
(12 V, 24 V, 48 V, 80 V - please specify)

- automatic lubrication system:
VDPK-C, VDRPK-C upon request

image shows VDPK 30-C with optional high visibility load backrest



Multi fork positioner

with load-extender for 1-2 and 1-2-3 pallets

The double fork positioner VDPK-C with load-extender can load and unload lorries from one side. Additionally, the attachment has all the advantages of the double fork positioner, i.e. sideshift, slim forks, handling of one or two pallets and positioning the pallets together. The stroke of the load-extender is sufficient for the standard vehicle width of 2400 mm. Model VDRPK-C made for handling of 1, 2 or 3 pallets.

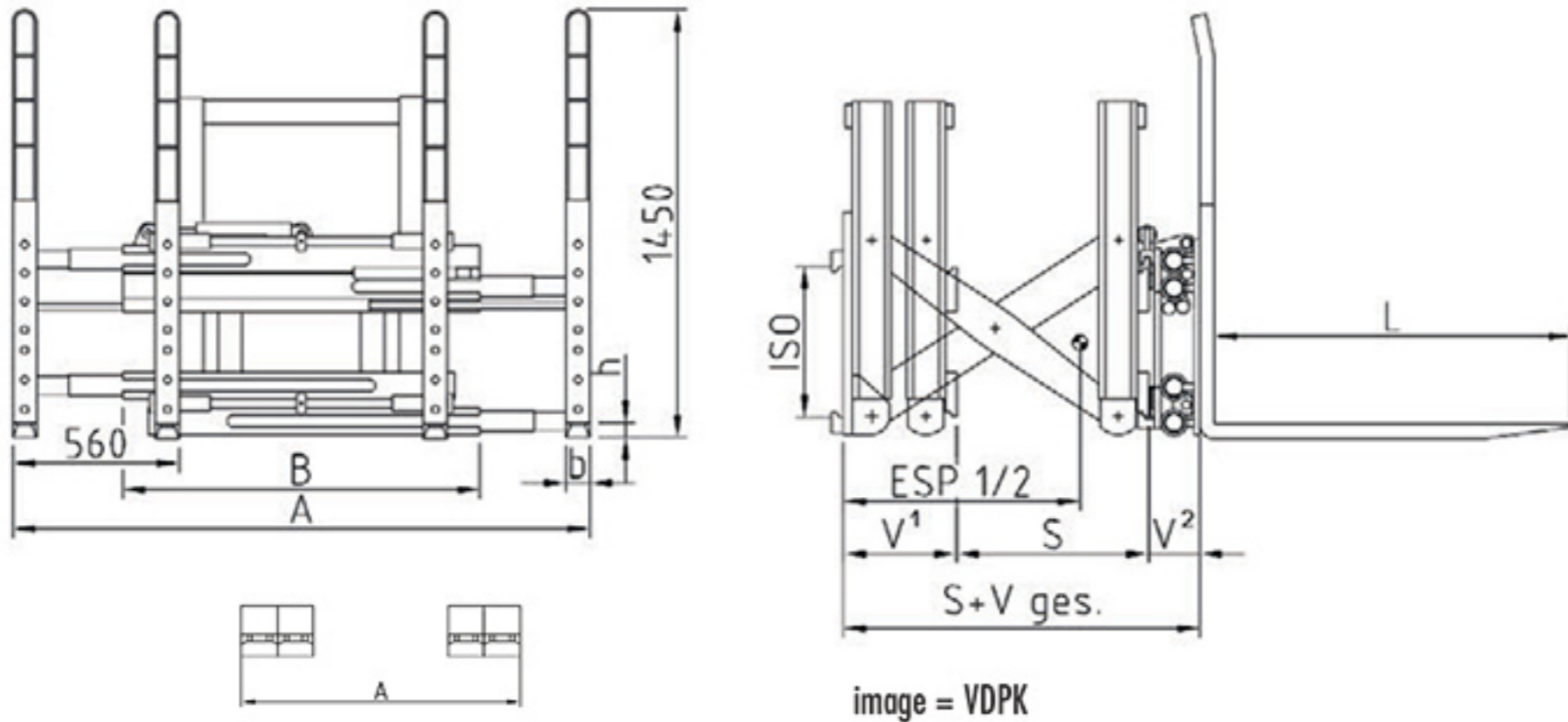

image = VDPK

double fork positioner for 1+ 2 pallets

type	capacity kg LC mm	lift truck to LC mm	ISO	B mm	A mm	forks b x h x L mm	stroke S mm	sideshift mm	V1+V2 LLC mm	ESP I COG I mm	ESP II COG II mm	weight kg
VDPK 25-C	800/1840	3,5/500	II/III	1200	560-1940	80x40x1200	620	+/- 100	520	340	870	970
VDPK 45-C	2200/1840	4,5- 5,0/600	III	1200	560-1940	80x50x1200	650	+/- 100	545	365	820	1160
VDPK 50-C	2200/1840	5,0/600	IV	1200	560-1940	80x50x1200	650	+/- 100	545	365	820	1180

triple fork positioner for 1, 2 and 3 pallets

type	capacity kg LC mm	lift truck to LC mm	ISO	B mm	A mm	forks b x h x L mm	stroke S mm	sideshift mm	V1+V2 LLC mm	ESP I COG I mm	ESP II COG II mm	weight kg
VDRPK 45-C	2500/1840	5,0/600	III	1550	560-2285	60x50x1200	650	+/- 125	553	400	680	1395
VDRPK 60-C	2600/1840	6,0/600	IV	1550	560-2285	60x60x1200	650	+/- 125	553	440	720	1455
VDRPK 70-C	2700/1840	7,0/600	IV	1550	560-2285	60x60x1200	650	+/- 125	553	455	735	1485
VDRPK 80-C	3600/1840	8,0/600	IV	1550	560-2285	60x60x1200	650	+/- 125	600	370	760	1880

- 3 hydraulic functions required
- includes hoses and couplings
- constant sideshift as standard

- solenoid valve upon request
(12 V, 24 V, 48 V, 80 V - please specify)

- automatic lubrication system:
VDPK-C, VDRPK-C upon request

image shows VDPK 30-C with optional high visibility load backrest



Multiple fork positioner for 4-6 pallets

SPK-C2

The multiple fork positioner **SPK-C** is ideal for picking up and transporting 4 or 6 pallets at one time. Despite the stable and robust construction it offers excellent visibility to the operator. The outer forks spread beyond the attachment frame width.

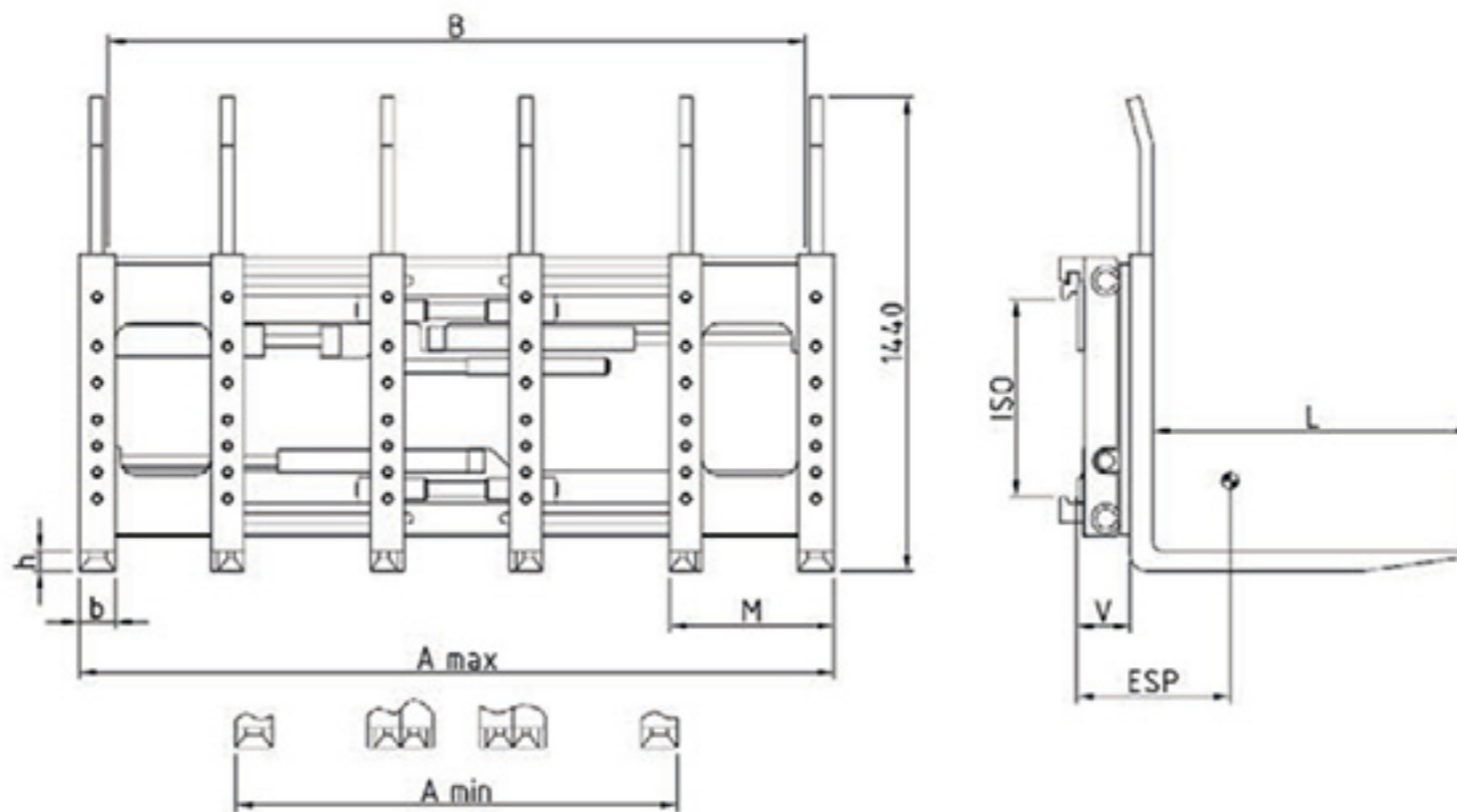

type	capacity kg LC mm	lift truck to LC mm	ISO	B mm	A mm	M mm	forks b x h x L mm	sideshift mm	ESP COG mm	V LLC mm	weight kg
SPK 60-C2	3000/1200	6,0/600	IV	1860	1340-2290	500	80x60x2400	+/- 160	520	162	1450
SPK 80-C2	4000/1200	8,0/600	IV	1860	1340-2290	500	120x70x2400 80x70x2400	+/- 160	560	162	1660
SPK 100-C2	6000/1200	8,0/900	IV	1860	1340-2290	500	120x70x2400 80x70x2400	+/- 160	550	174	1880
SPK 100-C2	6000/1200	8,0/900	IV	2260	1340-2700	500	120x70x2400 80x70x2400	+/- 160	535	174	1945

- 2 hydraulic functions required
- includes hoses and couplings

- constant sideshift as standard



automatic lubrication system: upon request



DURWEN 
Forklift Attachments

More than 70 years experience

Multiple fork positioner for 2-3-4 and 6-8 pallets

The multiple fork positioner **VPK-C** can pick up 2, 3 or 4 pallets through hydraulic fork positioning.

The multiple fork positioner **APK-C** can pick up 4, 6 or 8 pallets. Both models give excellent visibility to the operator. The stable frame gives strong support to the forks and allows high goods turnover. Sideshift is fitted as standard.

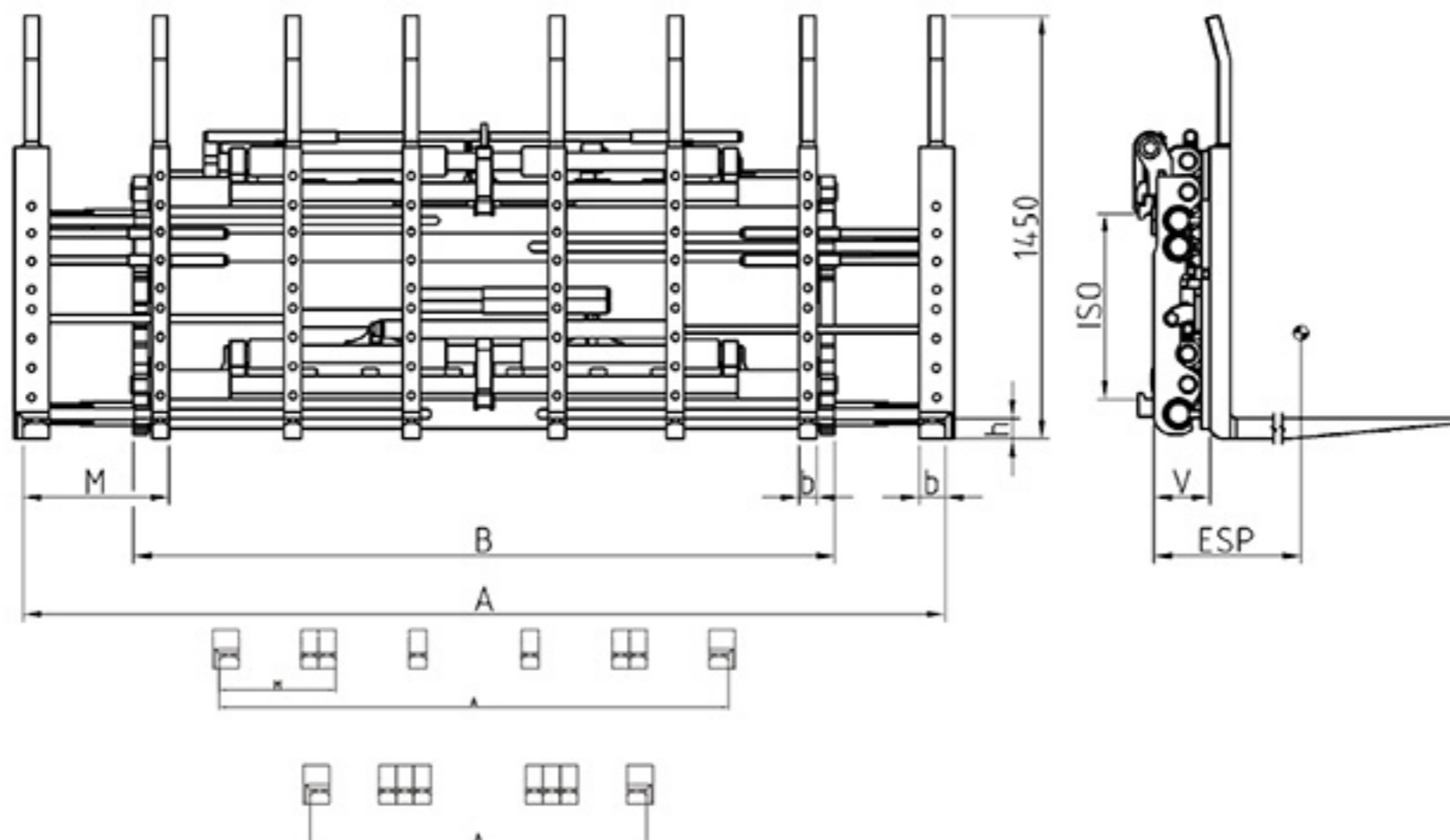

type VPK for 2-3-4 pallets

type	capacity kg LC mm	lift truck to LC mm	ISO	B mm	A mm	M mm	forks b x h x L mm	sideshift mm	V LLC mm	ESP COG mm	weight kg
VPK 50-C	3600/600	5,0/600	IV	2400	1360-3155	500	80x60x1200	+/- 150	189	210	1390

type APK for 4-6-8 pallets

type	capacity kg LC mm	lift truck to LC mm	ISO	B mm	A mm	M mm	forks b x h x L mm	sideshift mm	V LLC mm	ESP COG mm	weight kg
APK 80-C	5600/1200	8,0/900	IV	2400	1760-2960	500	120/90x70x2400 60x70x2400	+/- 150	200	435	2240

- 2 hydraulic functions required
- includes hoses and couplings

- constant sideshift as standard



automatic lubrication system:
upon request

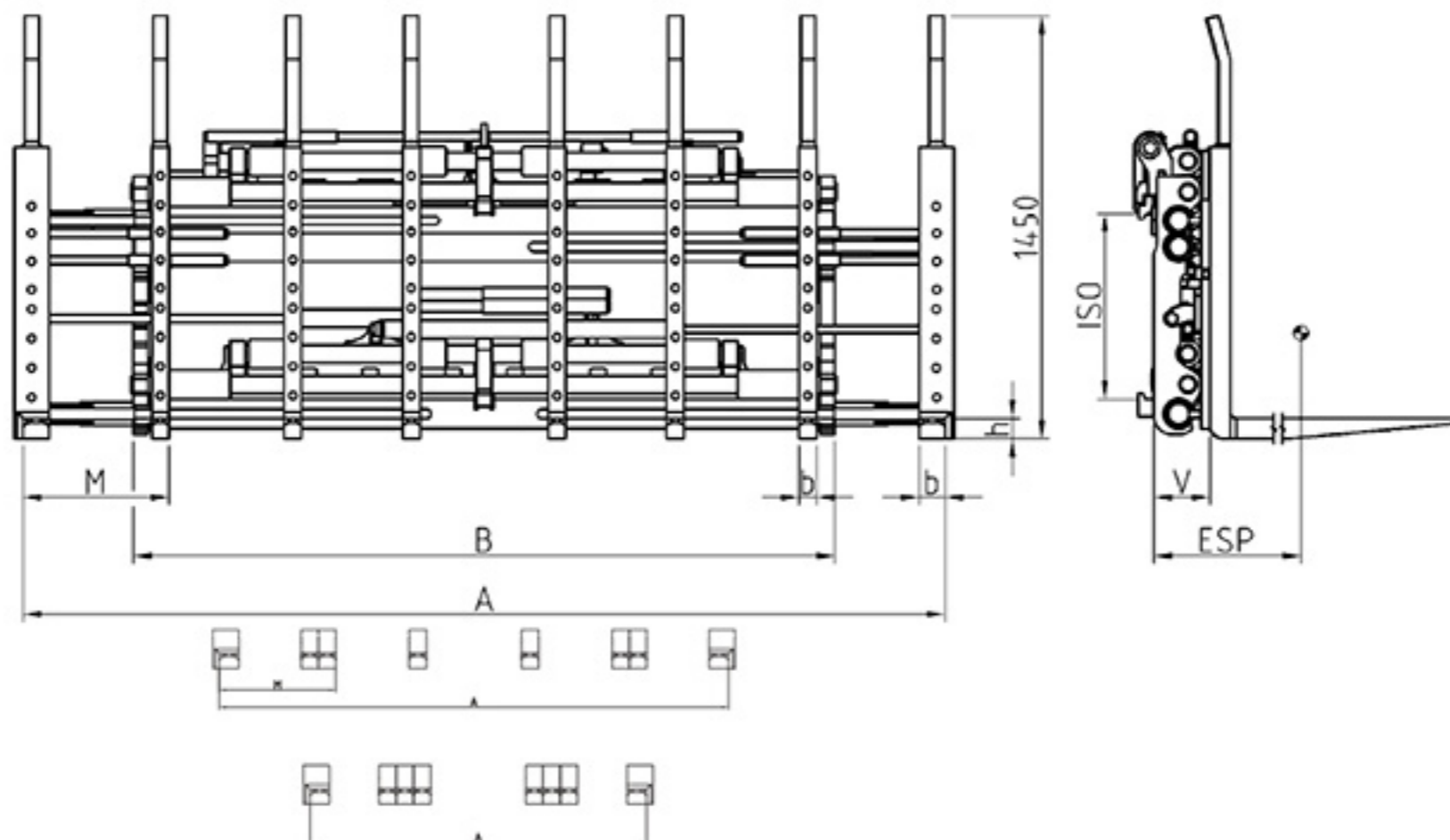

image shows APK 80-C with special equipment: telescopic camera

Multiple fork positioner for 2-3-4 and 6-8 pallets

The multiple fork positioner **VPK-C** can pick up 2, 3 or 4 pallets through hydraulic fork positioning.

The multiple fork positioner **APK-C** can pick up 4, 6 or 8 pallets. Both models give excellent visibility to the operator. The stable frame gives strong support to the forks and allows high goods turnover. Sideshift is fitted as standard.



type VPK for 2-3-4 pallets

type	capacity kg LC mm	lift truck to LC mm	ISO	B mm	A mm	M mm	forks b x h x L mm	sideshift mm	V LLC mm	ESP COG mm	weight kg
VPK 50-C	3600/600	5,0/600	IV	2400	1360-3155	500	80x60x1200	+/- 150	189	210	1390

type APK for 4-6-8 pallets

type	capacity kg LC mm	lift truck to LC mm	ISO	B mm	A mm	M mm	forks b x h x L mm	sideshift mm	V LLC mm	ESP COG mm	weight kg
APK 80-C	5600/1200	8,0/900	IV	2400	1760-2960	500	120/90x70x2400 60x70x2400	+/- 150	200	435	2240

- 2 hydraulic functions required
- includes hoses and couplings

- constant sideshift as standard



automatic lubrication system:
upon request



image shows APK 80-C with special equipment: telescopic camera